



Installation, Operation & Maintenance Manual

MMX Series UTILITY MIXER

Important Safety Instructions

This Installation and Operation Manual Includes **Important Warnings and Safety Information.**

Be sure to keep this manual with equipment and ensure all operators read the enclosed information.

Table of Contents

Important Safety Warnings	1
Receiving, Inspection & Storage.....	3
Operation Instructions.....	4
Start-up Checklist.....	5
Assembly & Installation.....	6
MMX Mixer Mounting Types	6
Parts, Maintenance & Service	7
Technical Assembly Drawing	7
General Information Regarding Electric Motors	8
General Information Regarding Air Motors	10
Troubleshooting Guide	13
Terms & Conditions	14
Warranty	15



*MMX SERIES
Portable Mixer*

Dynamix Agitators Inc.

150 - 14480 River Road,
Richmond, B.C, Canada V6V 1L4
Ph. 604.244.3771 Fax 604.244.3772

info@dynamixinc.com
www.dynamixinc.com

Important Safety Warnings

Please Read These Warnings Carefully Before Unpacking the Mixer



The following safety instructions must be **COMPLETELY REVIEWED AND FOLLOWED** before operating any Dynamix Mixer. **FAILURE TO FOLLOW THESE INSTRUCTIONS COULD RESULT IN SERIOUS INJURY**

In the installation, operation and maintenance of the Mixer, SAFETY comes first.

ALL safety precautions listed in this manual MUST be followed by all personnel working on or with the equipment if serious injury is to be avoided.

1. This mixer is intended for professional use only.
2. The installation of this equipment does not normally require the services of factory personnel. If required, these services can be agreed upon before or after purchase. These services are available from Dynamix Agitators by contacting the Sales Department.
3. Adequate installation, maintenance, and safety instructions must be given by the operator to personnel directly responsible for the operation of the drive and accessory equipment. In addition, the procedures set forth in the operating instructions must be carefully followed.
4. All service personnel **MUST** be knowledgeable relative to the equipment before performing any maintenance or repair work. Use proper clothing, tools and methods of handling to prevent serious accidents.
5. The operator is responsible for furnishing and installing any guards or other safety equipment needed to protect operating personnel as required by Occupational Safety and Health Administration standards (OSHA) or other applicable safety regulations. This equipment normally is not furnished by Dynamix Agitators except when specified as part of the order. In all cases, however, the operator has the responsibility of complying with all local, state / province and national fire, electrical, and safety regulations when installing the equipment.
6. Each mixer is selected for a specific application. **Do not use this mixer in applications other than that for which was designed and quoted. Applying a mixer in applications outside of intended use may result in overload conditions, which will damage the mixer.** If you are unsure of the appropriate application, please contact Dynamix Agitators with the relevant mixer serial number.
7. Do not connect to air motor to power source until this Manual is followed and the mixer is properly assembled and installed as per design.
8. Your mixer has been tested and checked for shaft straightness before shipping. Care must be taken while handling the shaft to ensure proper operation.
9. Do not alter or modify this mixer. Any alteration or modification will void the mixer's Warranty.
10. If the mixer features a detachable coupling, ensure that the coupling is fully engaged and seated in the fully rotated position of the coupling lock (rotated 10 degrees).
11. Ensure all equipment and personnel are clear of all rotating parts.
12. Do not touch rotating mixer parts.
13. If your mixer requires lifting by eyebolt or by another method, ensure that eyebolts or other means are securely fastened before lifting the mixer.
14. Some electric motors will run excessively hot under continued load. Always use lifting handles to lift modular drive segments off their coupling.

15. Do not exceed the working air pressure of 100 psi for air motors
16. Check equipment daily. Repair and replace damaged parts immediately.
17. Do not uninstall or service this mixer until you have followed your "Control of Hazardous Energy Sources" procedure as per OSHA Guidelines and/or the Canadian Occupational Health and Safety Regulations.



FIRE AND EXPLOSION HAZARD

Improper grounding, poor ventilation, open flames, or sparks can cause a hazardous condition and result in a fire or explosion and serious injury.

Receiving, Inspection & Storage

Please Read These Warnings Carefully Before Unpacking the Mixer



The following safety instructions must be **COMPLETELY REVIEWED AND FOLLOWED** before operating any Dynamix Mixer. **FAILURE TO FOLLOW THESE INSTRUCTIONS COULD RESULT IN SERIOUS INJURY**

Goods must be inspected with 30 days of receive date. It is assumed that goods are satisfactory if Dynamix is not notified within this period.

Your mixer has been tested and checked for shaft straightness before shipping. Care must be taken while handling the shaft to ensure proper operation.

Please follow the following steps to prevent injury or damage to equipment:

1. Immediately upon delivery, check all crating and boxes for damage which may have occurred during transit, and report any damage to the carrier and Dynamix Agitators Inc.
2. Carefully inventory all furnished equipment against packing list to determine if any shortages exist in delivered material. Any such shortages must immediately be reported to Dynamix Agitators and the Carrier if a timely claim is to be made.
3. The Dynamix Factory has tested and checked this mixer for operation and shaft straightness before shipping. Care must be taken when handling this mixer to ensure proper operation and longevity.
4. Store the mixer in a clean, dry environment, with a relatively constant temperature. Electric motors are easily damaged by moisture. Circulating air will help prevent moisture buildup in the mixer.
5. Store the mixer assembly off the floor, covered by plastic.
6. Do not seal the plastic covering as this will increase the chance of condensation. Use desiccants if possible.



MOVING PARTS HAZARD

Always shut off the mixer power source (unplug electric power and disconnect air power source) before performing any maintenance, repair, or adjustments. Not doing so can result in serious injury.

Operation Instructions

Please Read These Warnings Carefully Before Operating the Mixer



The following safety instructions must be **COMPLETELY REVIEWED AND FOLLOWED** before operating any Dynamix Mixer. **FAILURE TO FOLLOW THESE INSTRUCTIONS COULD RESULT IN SERIOUS INJURY**

Important: This instruction manual is not intended to include a comprehensive listing of all details for all procedures required for installation, operation and maintenance. If you have a question about a procedure or are uncertain about any detail, **Do Not Proceed**. Please contact Dynamix Agitators for more information or clarification.

1. Do not uninstall or service this mixer until you have followed your “Control of Hazardous Energy Sources” procedure as per OSHA Guidelines and/or the Canadian Occupational Health and Safety Regulations.
2. Read and fully understand the manual before installation and start-up.
3. Ensure the mixer is designed for the application. Operating outside of the mixer's intended use will result in damage. Refer to original quotation.
4. Do not handle the mixer by the shaft. Lifting and handling the mixer by the shaft will cause damage.
5. Check the straightness of the shaft by slowly rotating by hand before operation in fluid.
6. On start-up jog the mixer in order to ensure the mixer shaft and impeller is not obstructed from rotation.
7. Fluid level **must** be a minimum of the equivalent to one diameter above the impeller for proper mixing. **Avoid operating the mixer in air.**
8. Avoid extended operation when fluid level is at or near the bottom impeller
9. Fluidize settled solids before starting mixer. Impeller cannot be buried in solids at start-up.
10. If the impeller is buried, disperse any settled solids before starting the mixer. This may be done using an air hose, re-circulating pump, or a large stick.
11. When viewed from above (looking into the tote container), tote mixer rotation is counter-clockwise. Improper direction will result in minimal mixing.
12. Vortexing may occur if the fluid level is too close to the impeller. Aeration of the product and excess vibration may occur.
13. When mixing materials of different viscosities or specific gravities, the lighter or less viscous material should be introduced first. Add heavier materials gradually in the center of the tank while the mixer is running. **Do not dump large quantities of solids or powders into the tank.** This will cause impacting on the impeller and may cause equipment damage.
14. Some shaft vibration is normal. A bent shaft may cause excess vibration.
15. Keep motors clean and dry. Air motor intakes and exhaust ports must be clear of foreign material. The electric motors supplied are designed for outdoor use, but may be damaged due to weather. A rain cover may be added to extend motor life.
16. Do not run air motors above 2000 RPM. **See Page 11** for proper air consumption and pressure charts. See the **Technical Drawing** for the motor size.

Start-up Checklist

Please Review This Checklist Carefully Before Operating the Mixer

Prior to, and during start-up, please check that the following things have been done:

1. **Manual has been read and followed**
2. Drive coupling is fully engaged
3. Sufficient protection for motor (*if outdoors*)
4. Wiring correctly installed, grounded, and insulated
5. Impeller(s) installed correctly. See Installation section of Manual.
6. Impellers spaced correctly (*if two or more*) for maximum and minimum liquid levels
7. Impeller immersed in liquid and no equipment or obstructions can impact the impeller
8. Mounting nut is threaded down and tight (tote design only)
9. Proper shaft rotation (*counter clockwise looking down, unless otherwise noted*)
10. Correct voltage / amperage upon starting
Check against motor nameplate data: Record: _____ Volts _____ Amps
11. Excessive noise after start-up? Record: _____ db @ 3ft
12. Excessive vibration of tank or support

Inspector

Date

Assembly & Installation

MMX Mixer Mounting Types

2" NPT "Bung" Mount

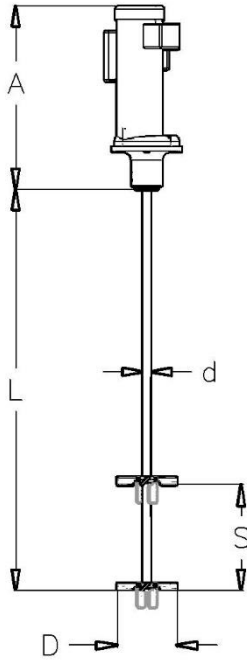

Figure 1

Light Duty Clamp Mount

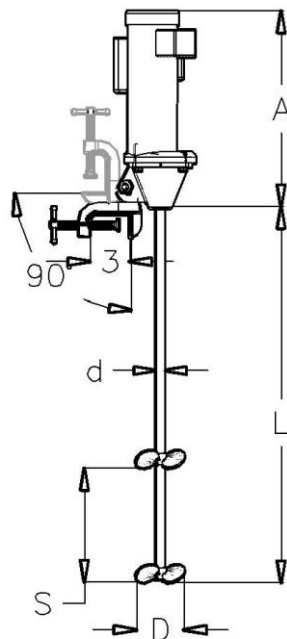

Figure 2

Drum Lid Mount

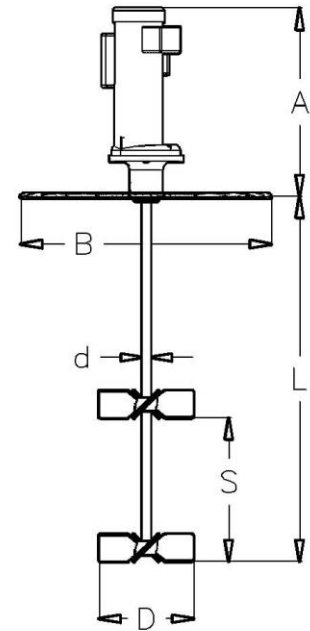

Figure 3

Universal Drum Mount

(a) Closed Drum

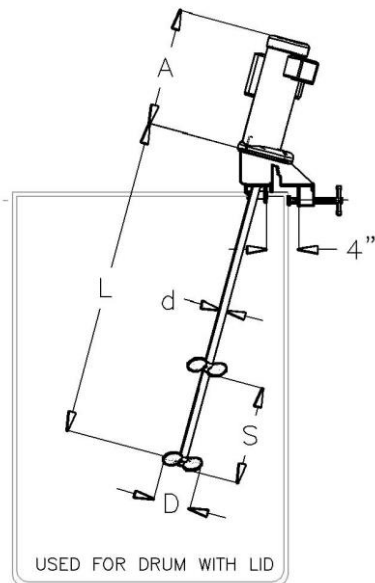

Figure 4

(b) Open Drum

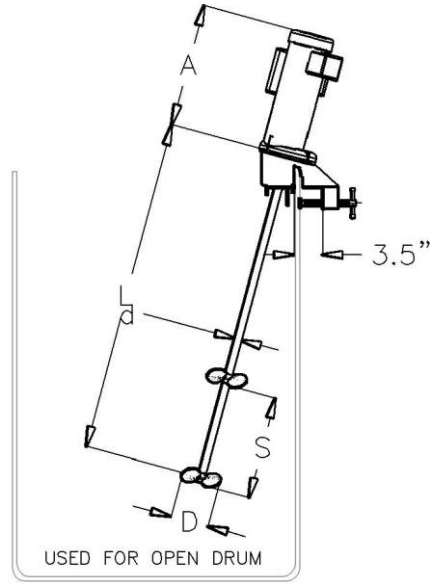

Figure 5

Parts, Maintenance & Service

Technical Assembly Drawing

This drawing is not exact.

It is only a typical representation of the MMX Series models. When noted, please contact your Dynamix representative with your mixer serial number. Note; the MMX Series is a highly configurable mixer and few parts are standard.

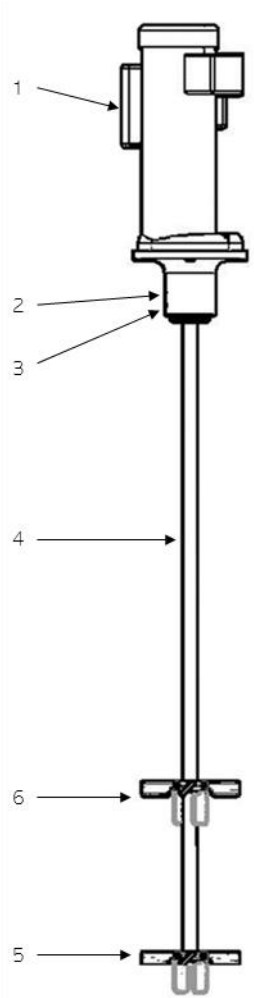

REF #	PART NAME	PART No.
1	GEARMOTOR	Refer to mixer serial no. or sales person to confirm specs.
2	BUNG MOUNT	Refer to mixer serial no. or sales person to confirm specs.
3	SHAFT COUPLING	Refer to mixer serial no. or sales person to confirm specs.
4	SHAFT ASSEMBLY	Refer to mixer serial no. or sales person to confirm specs.
5	BOTTOM IMPELLER	Refer to mixer serial no. or sales person to confirm specs.
6	TOP / MIDDLE IMPELLER	Refer to mixer serial no. or sales person to confirm specs.

All equipment design and application data shown herein and related info is confidential and the property of Dynamix Agitators Inc. No use or disclosure thereof may be made without written permission from Dynamix Agitators Inc.

General Information Regarding Electric Motors

Overview

For your protection, do not install, operate or attempt to perform maintenance procedures until you understand the Warning and Caution statements. A Warning statement indicates a possible unsafe condition that can cause harm to personnel. A Caution statement indicates a condition that can cause damage to equipment.

Before you operate or perform maintenance, become familiar with the following:

1. NEMA Publication MG-2, Safety Standard for Construction and Use of Electric Motors
2. The National Electrical Code
3. Local codes and Practices
4. "Control of Hazardous Energy Sources" procedure as per OSHA Guidelines, and the Canadian Occupational Health and Safety Regulations

Motor Enclosures

TEFC, totally enclosed motors are intended for use where moisture, dirt and/or corrosive materials are present in indoor and outdoor locations.

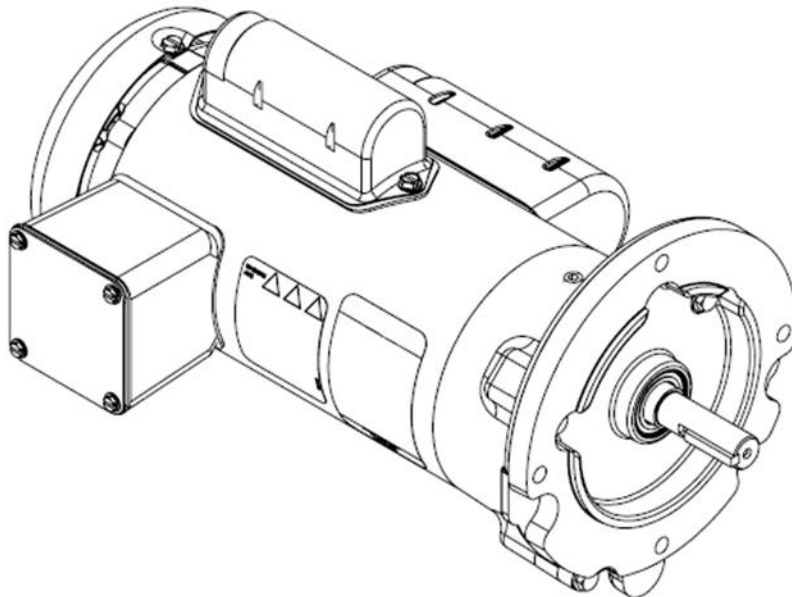

Safety Notice

This equipment contains **high voltage! Electrical shock can cause serious or fatal injury.** Only qualified personnel should attempt installation, operation and maintenance of electrical equipment. Be sure that you are completely familiar with NEMA publication MG-2, safety standards for construction and guide for selection, installation and use of electric motors and the National Electrical Code and local codes and practices. Unsafe installation or use can cause conditions that lead to serious or fatal injury.

Only qualified personnel should attempt the installation, operation and maintenance of this equipment.

 <p>WARNING!</p>	<ul style="list-style-type: none">• Do not touch electrical connections before you first ensure that power has been disconnected. Electrical shock can cause serious or fatal injury. Only qualified personnel should attempt the installation, operation and maintenance of this equipment.• Be sure the system is properly grounded before applying power. Do not apply AC power before you ensure that all grounding instructions have been followed. Electrical shock can cause serious or fatal injury. National Electrical Code and Local codes must be carefully followed.• Use proper care and procedures that are safe during handling, lifting, installing, operating, and maintaining operations. Improper methods may cause muscle strain or other harm.• Disconnect all electrical power from the motor windings and accessory devices before disassembly of the motor. Electrical shock can cause serious or fatal injury.• Do not use these motors in the presence of flammable or combustible vapors or dust. These motors are not designed for atmospheric conditions that require explosion proof operation.• Motors that are to be used in flammable and/or explosive atmospheres must display the on the nameplate the UL label showing the correct classification for the area it is operated in. Specific service conditions for these motors are defined in NEC 70-599.• To prevent equipment damage, be sure that the electrical service is not capable of delivering more than the maximum motor rated amps listed on the rating plate.
--	--

Motor Connections

1. **Wiring:** Match the motor starter and overload protection to the motor rating. Follow the control manufacturer's instructions.
2. All electrical connections must conform to National Electrical Code and all local regulations. Match line voltage and wire capacity to motor rating found on the motor nameplate.
3. Single-phase electric motors may be pre-wired with a six (6) foot electrical cord. If not provided, follow the wiring diagram on the motor for proper connections. Ensure the switch is in the OFF position before connecting to a power supply. Switch the connections to achieve proper rotation.
4. Three phase electric motors must be wired according to the diagram on the motor.
5. Variable speed DC motors using an SCR controller must be wired following the controller instructions. Before applying power, read the instructions carefully, and make the required adjustments.
6. Mixer standard rotation direction is counter-clockwise facing lead end.

General Information Regarding Air Motors

Air motors operate best with lubricated, dry, clean air at air pressures below 100psi.

Air Lubricator: Lubricated air is typically available from the air system. If not, an automatic lubricator must be installed in the air- line ahead of the air motor. Use a pneumatic air lubricant e.g. ISO VG32 or detergent SAE #10 automotive oil. Lubricator should be adjusted to feed one drop of oil for every 50 to 75cfm.

Moisture: Excessive moisture in the air-line can cause rust formation in the motor and ice to form in the muffler. An in-line separator must be used on your pneumatic system to reduce this.

Air Filter: If the air is dirty this will cause the motor to run sluggishly and can break the motor vanes. An in-line filter must be used on your pneumatic system to reduce this.

Pressure Regulator: Air motors are designed to operate with a maximum air pressure of 100 psi. If higher air pressure is supplied, an in-line air pressure regulator should be used to reduce the pressure. This can also be used to vary the speed of the air motor

Flushing: Should excessive dirt, foreign particles, moisture, or excess oil be permitted to enter the air motor, the unit will act sluggish. Flushing the air motor should remove this.

 <p>WARNING!</p>	<ul style="list-style-type: none">• Use only non-combustible solvents.• Do not use kerosene or other flammable solvents to flush the air motor.• Flushing with Flammable solvents could cause fire or explosion and result in serious injury or property damage.• Using GAST Flushing Solvent AH255D will reduce this concern.• Wear eye protection and flush in a well-ventilated area.
--	--

1. Disconnect air line and muffler
2. Pour several tablespoons of solvent directly into intake port
3. Rotate shaft by hand in both directions for 3 to 4 minutes
4. Reconnect air line and slowly apply pressure until there is no trace of solvent in the exhaust air
5. Re-lubricate motor with a squirt of oil in chamber

Air Motor Horsepower Rating & Air Consumption

For Air Motors Rated at 1.5HP

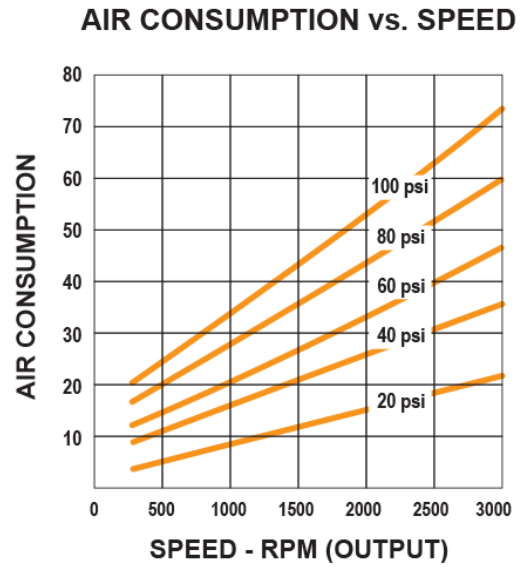
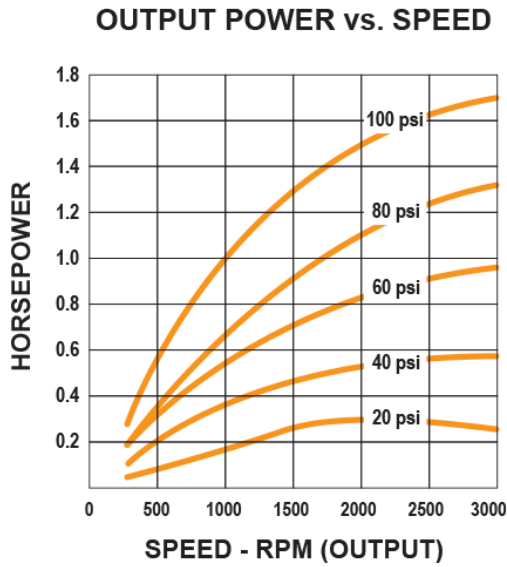

For Air Motors Rated at 4HP

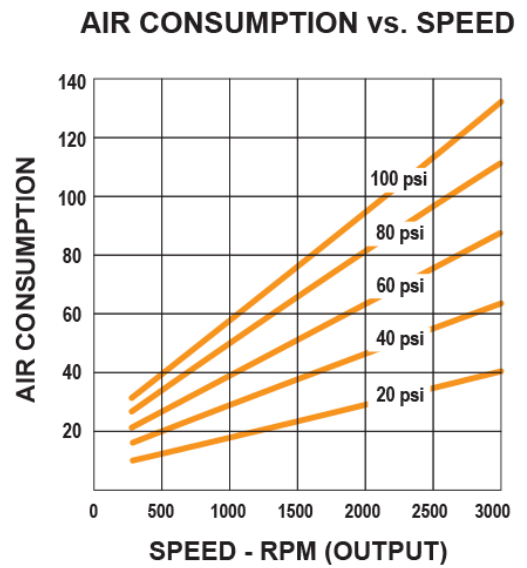
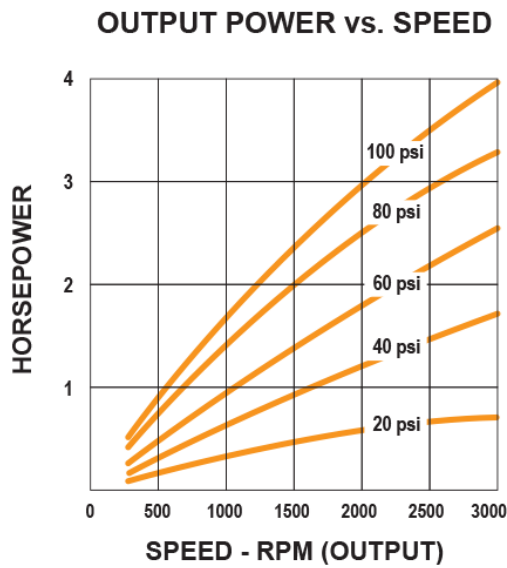

Note: Output rpm refers to motor output shaft only. For gear reduced drives refer to gear ratio on quotation.

Lubrication

Air Motor Connection

Air Motors must always have a filter, lubricator and moisture trap installed on the air supply line. Supply pipe should be one size larger than the intake port on the motor. A regulator may be installed to control motor speed. Install the airline on the correct port on reversible motors for proper rotation direction.

Air Motor

Air Motor lubricator should be adjusted to feed one drop of oil every 50-75 CFM.

Use SAE #10automotive detergent engine oil.

Gear Driven

Gear drivers for mixers are lubricated at the factory using the proper type and amount of lubricant for normal service, and are maintenance free. For additional information contact Dynamix Agitators.

Mixer Shaft Bearings

Mixer Shaft Bearings are pre-lubed and sealed and do not require re-lubrication.

Troubleshooting Guide

Use This Chart to Diagnose Operation Issues

Problem	Possible Cause	Possible Solution
Mixer Will Not Start	<ul style="list-style-type: none"> Loose connections Incorrect wiring Blown fuse Wrong size heaters in starter Mechanical jamming Water damage to motor 	<ul style="list-style-type: none"> Check and tighten connection Check wiring diagram and wire correctly Replace fuse Replace heaters Free all debris for rotation Service or replace motor
Motor Runs Hot	<ul style="list-style-type: none"> Restricted ventilation Amperage overload Low or high voltage Unbalanced voltage between phases Frequent starting and stopping Product too viscous Impeller(s) upside down Incorrect rotation 	<ul style="list-style-type: none"> Clear the vents CONSULT FACTORY Wire for correct voltage Consult electrician Check with factory – a special motor may be required Check viscosity and specific gravity of product (consult factory) Reinstall in correct position Change motor leads per nameplate instructions
Mixer Will Not Reach Correct Speed	<ul style="list-style-type: none"> Overload of motor Loose drive coupling bolts <i>Also See: "Mixer Will Not Start"</i> 	<ul style="list-style-type: none"> Check amperage against nameplate data Check coupling bolt tension (coupling and/or shaft may be damaged if mixer has been run with slipping coupling)
Shaft Will Not Fit Into Drive	<ul style="list-style-type: none"> Shaft over size (proper diameter: 0.001" – 0.002" under normal diameter) Wrong end of shaft (only one end fits) (2) Coupling bolts are too tight Wrong size shaft, coupling or bearing Damaged shaft, coupling or bearing 	<ul style="list-style-type: none"> Measure and consult factory Install end marked motor end Loosen bolts CONSULT FACTORY CONSULT FACTORY
Shaft Vibration	<ul style="list-style-type: none"> Unstable mounting platform Bent mixer shaft Bent or uneven impeller blades Impeller not immersed in liquid Impeller too close to surface Worn or damaged drive bearings 	<ul style="list-style-type: none"> Reinforce platform CONSULT FACTORY CONSULT FACTORY Fill tank Fill tank and lower impeller (see S3) Replace damaged parts
Noisy Operation	<ul style="list-style-type: none"> Foreign material in lubricant Dry lip seal in spool Insufficient lubricant Incorrect lubricant Loose drive coupling bolts Worn or faulty bearings/gears 	<ul style="list-style-type: none"> Change lubricant Apply lubricant to lip seal Fill proper amount of lubricant Change to correct lubricant Check and tighten coupling bolts Check bearings/gears – replace if necessary
Oil Leakage	<ul style="list-style-type: none"> Damaged broken gasket Excessive lubricant Seals worn or damaged Loose bolts around side plates 	<ul style="list-style-type: none"> Replace gasket Check manual for proper amount of lubricant and drain excess Replace seals Check and tighten bolts
Bearing Failure	<ul style="list-style-type: none"> Water damage High temperature product <i>Also See: "Noisy Operation"</i> 	<ul style="list-style-type: none"> Replace bearings (check all other parts) Provide heat shield CONSULT FACTORY

Terms & Conditions

These Delivered Terms and Conditions (the “Delivered Terms”) apply to the purchase of Dynamix Agitators Inc. (“**Dynamix**”, “**We**” or “**Our**”) products (“**Products**”) by a customer (the “**Customer**”). Unless otherwise indicated, these terms and conditions will apply to all purchases of Products from Dynamix.

PURCHASE TERMS

The Customer’s purchase of Products is governed by: (1) the quotation sent to the Customer for the Products, which sets out the Customer’s name and address, the Products covered, price and payment terms (the “**Quotation**”); (2) the terms and conditions attached to the Quotation; (3) these Delivered Terms; and (4) any additional terms referenced in the Quotation (collectively, the “**Agreement**”).

CONFIDENTIAL INFORMATION

The Product pricing, terms and conditions of sale, the Quotation, and other information contained in or disclosed by Dynamix pursuant to the Agreement is confidential. Customer may not disclose such pricing, terms and conditions, Quotation and other information to any other party without Dynamix’s prior written approval, except for any legally required disclosures. Dynamix reserves the right to enforce these confidentiality restrictions against any party who wrongfully discloses, receives or further disseminates Dynamix’s confidential information.

LIMITATION OF REMEDIES

Customer’s remedy for breach of any of the foregoing warranties shall be limited to those set forth in the **Warranty Section** provided below, however, that We will not be responsible for removal, loading, installation, freight or similar related expenses in connection with any modification, replacement or repair. The determination of which remedy shall be applicable, shall be determined by Dynamix, in its sole discretion.

DYNAMIX AND ITS AFFILIATES AND REPRESENTATIVES HAVE NO LIABILITY TO CUSTOMER FOR ANY DIRECT, INDIRECT, SPECIAL, PUNITIVE, INCIDENTAL OR CONSEQUENTIAL DAMAGES OR DELAY WHATSOEVER, INCLUDING, BUT NOT LIMITED TO, DAMAGES FOR LOST OR INTERRUPTED BUSINESS, LOSS OF USE, LOST PROFITS OR LOST REVENUES, HOWEVER CAUSED AND UNDER ANY THEORY OF LIABILITY (INCLUDING, BUT NOT LIMITED TO, CONTRACT, TORT, WARRANTY OR NEGLIGENCE), EVEN IF WE HAVE BEEN ADVISED OF THE POSSIBILITY OF SUCH DAMAGES. THE TOTAL LIABILITY OF DYNAMIX AND ITS AFFILIATES AND REPRESENTATIVES TO CUSTOMER AND CUSTOMER’S EXCLUSIVE REMEDY FOR ANY AND ALL CLAIMS ARISING OUT OF OR RELATING TO THIS CONTRACT, INCLUDING, BUT NOT LIMITED TO, THE PRODUCTS PROVIDED HEREUNDER, IS LIMITED TO THE PURCHASE PRICE OF THE PRODUCT THAT IS THE BASIS FOR THE CLAIM.

Customer will be barred from any remedy unless Customer gives Dynamix prompt written notice of the problem. Further, any returns of Products for modification, repair or replacement must be authorized by Dynamix in writing prior to return of the Products by the Customer.

Dynamix will not be responsible for any repairs performed by third parties unless the extent, or terms and costs of such repairs, are authorized by Dynamix, in writing in advance.

PATENTS

Dynamix represents and warrants that, to its knowledge, the Products do not infringe upon any patents granted to others. We do not assume any responsibility or liability for any claim of infringement brought against the Customer, its successors, assigns, customers or users of the Products.

UNAUTHORIZED MODIFICATIONS

Modifications to the Products ordered by Customer, or any of their components, could significantly affect their performance or conformance to Dynamix’s features. Any modification of the Products, or any of their components, other than as performed or authorized in writing by Dynamix, is prohibited and will invalidate and terminate Dynamix’s warranty for the Products, effective on the date of any such modification.

LEGAL FEES

If a suit or action is brought by any party under this Contract to enforce or interpret any of its terms or in any appeal therefrom, it is agreed that the prevailing party shall be entitled to reasonable legal fees to be fixed by the trial court and/or appellate court. Customer shall be responsible for any and all costs of collection incurred by Dynamix in connection herewith, including legal fees and costs.

JURISDICTION / VENUE

These Delivered Terms will be governed by and construed in accordance with the laws in force in the Province of British Columbia and the federal laws of Canada, as applicable therein, without regard to its conflict of laws principles. The Parties agree to attorn to the exclusive jurisdiction of the courts of British Columbia.

GENERAL MATTERS

Any assignment of these Delivered Terms will be void without the other party's prior written consent, which will not be unreasonably withheld. Dynamix may hire subcontractors or use its affiliates to perform the obligations under this Agreement. If any part of these Delivered Terms are found invalid, the remaining part will be effective. No waiver, alteration or modification of any of the provisions of these Delivered Terms will be binding on Dynamix, unless made in writing and signed by a duly authorized officer of Dynamix. These Delivered Terms, the Quotation and its attached terms and conditions, and any other terms referenced in the Quotation contain the entire agreement of the parties.

Warranty

Dynamix warrants to the Customer that the Product will perform substantially in accordance with the features and Solution Assurance as set out in the Quotation and be free from defects in materials and workmanship under normal use.

We warrant that we will modify, repair or replace the Product provided to the Customer, at Our sole discretion and at no charge, Ex Works (Incoterms 2000) Dynamix plant, if the Product is defective in materials or workmanship under normal use.

WE DO NOT GUARANTEE THE PRODUCTS AGAINST CHEMICAL OR ABRASIVE ATTACK OR OTHER DETERIORATION DUE TO EXPOSURE.

THE FOREGOING WARRANTIES EXTEND ONLY FOR 12 MONTHS AFTER FIRST INSTALLATION OF THE PRODUCT AT CUSTOMER'S FACILITY OR FOR 18 MONTHS AFTER ITS SHIPMENT FROM DYNAMIX'S PLANT, WHICHEVER PERIOD IS SHORTER, OR AS OTHERWISE STATED IN WRITING BY DYNAMIX.

EXCEPT AS EXPRESSLY PROVIDED IN THE AGREEMENT, WE EXPRESSLY DISCLAIM AND MAKE NO EXPRESS OR IMPLIED REPRESENTATIONS, CONDITIONS, GUARANTEES OR WARRANTIES OF ANY KIND, ORAL OR WRITTEN, INCLUDING, BUT NOT LIMITED TO, IMPLIED WARRANTIES OF MERCHANTABILITY, FITNESS FOR A PARTICULAR PURPOSE, NON-INFRINGEMENT, INTER-OPERABILITY OF PRODUCTS, USAGE, CUSTOM OR TRADE, AND OF ALL OTHER OBLIGATIONS OR LIABILITIES ON THE PART OF DYNAMIX. THE ABOVE WARRANTIES SHALL NOT APPLY TO FAILURES RESULTING FROM (A) NORMAL WEAR AND TEAR, (B) ACCIDENT, NEGLIGENCE, ALTERATION, ABUSE, MISUSE OR USE INCONSISTENT WITH ANY INSTRUCTIONS PROVIDED AS TO STORAGE, HANDLING, MAINTENANCE, LUBRICATION, INSTALLATION, STARTUP, OPERATION AND SAFETY, (C) IMPROPER INSTALLATION AND/OR (D) INACCURATE AND/OR INCOMPLETE SPECIFICATIONS, DESIGN CONDITIONS OR OTHER DATA FURNISHED BY OR ON BEHALF OF CUSTOMER. WE MAKE NO WARRANTY WHATSOEVER WITH RESPECT TO ACCESSORIES OR PARTS NOT SUPPLIED BY DYNAMIX.

Warranty & Claims Policy

The following statement of our Warranty and Claims Policy is intended to assist our customers in understanding the terms of our warranty, the circumstances under which we will honor claims, and the procedure for making claims.

Our Warranty and Claims Policy should be read in conjunction with and is subject in as respect to the Terms and Conditions of Sale which appear on our quotation and acknowledgment forms and the specific terms of any distributorship or other such agreement between us and the individual customer.

1. Warranty Manufactured Products

We warrant Products manufactured by us to be free from defects in material and workmanship for a period of twelve (12) months after first installation of mixer or for eighteen (18) months after shipment from our factory, whichever occurs first.

Our liability under this warranty or in connection with any other claim relating to our Products is limited to the repair, or at our option, the replacement or refund of the purchase price, of any Products or parts or components which are returned to us freight prepaid and which are defective in material or workmanship. Products or parts or components thereof, which are repaired or replaced by us will be returned to our customer freight collect.

2. Limitation of Liability

The only warranty that we offer our customers is that warranty which is set forth on our quotation and acknowledgment forms and which is summarized above.

WE DO NOT MAKE ANY OTHER EXPRESS WARRANTIES OR ANY IMPLIED WARRANTIES, INCLUDING ANY IMPLIED WARRANTY OF MERCHANTABILITY OR OF FITNESS FOR A PARTICULAR PURPOSE OR USE.

In addition, we do not assume and we expressly disclaim any liability for

- a. any SPECIAL, INDIRECT, INCIDENTAL, OR CONSEQUENTIAL DAMAGES which anyone may suffer as the result of the sale, delivery, servicing, use or loss of use, of any Product, or
- b. any charges or expenses of any nature which are incurred without our express written consent.

Our total liability under our warranty or in connection with any claim involving any Product is expressly limited to the purchase price of the Product in respect of which damages are unclaimed.

3. What Is Not Covered By Warranty: Damages and Claims for Which Dynamix Is Not Responsible

The Seller's Warranty applies insofar as the unit is operated within the rating and service conditions for which it was specifically sold. The Purchaser must prevent the existence of any destructive external conditions that might typically include vibratory loads, severe shock loading, mechanical or thermal overloads or other conditions that may adversely affect the operation. The gear drive must be installed and maintained in accordance with instructions and provided in this manual.

The following are examples of the kinds of defect which are not covered by Our warranty; defects which are caused by improper installation, improper or abnormal use or operation, or improper storage or handling; defects caused by our customer's failure to perform normal preventive maintenance; defects caused by repairs by persons not authorized by us; defects caused by modification alterations made by our customer; and any damage to our Product occurring while is in our customer's possession.

Since these are examples and not a complete list, we suggest that our customers contact our Customer Service Department if they have any question concerning the scope of our warranty.

Additional costs incurred by our customers because of delays in delivery are consequential damages for which we are not responsible.

Risk of loss or damage to our Products passes to our customer when we tender our Products to the carrier. Although we cannot process transit damage claims with any carrier on a customer's behalf, we will provide reasonable assistance to our customers when such claims arise.

4. Consultations with Customers

When so requested, our engineers and other personnel may consult with our customers concerning our Products. While our employees will offer their best judgment on any question, the ultimate responsibility for selecting that Product which will perform the functions and applications desired by the customer rests with the customer. As noted above, we make no warranty, express or implied, as to the fitness of any Product for any Product for any particular purpose or use.

5. How to Make a Claim

Within the limits of the terms and conditions set forth on our quotation and acknowledgment forms and in the Warranty and Claims Policy, we will honor reasonable and justified claims when adequate evidence is provided to show that our Product was defective.

Whenever a customer has a claim concerning a Product, the customer should contact the Customer Service Department.

CUSTOMERS SHOULD NOT RETURN ANY PRODUCTS OR PARTS OR COMPONENTS TO US WITHOUT FIRST CONTACTING US.

When contacting us, customers should have the following information available:

- a) Customer name, location, purchase order number and date of purchase
- b) Factory/Branch order number (serial number)
- c) Product/Model number
- d) Equipment installation date
- e) Equipment failure date
- f) Application or service of unit
- g) Details of claim

Dynamix will notify the customer whether it will be necessary to return the Product or part or component to us. If so, we will send the customer an "AUTHORIZED RETURN NUMBER" that must be attached to the product or part or component before returning it. All items returned to us must be returned freight prepaid.

If we determine that the Product or part or component is defective and that the defect is covered by our warranty, we will, as explained above, correct the defect or refund the purchase price.

Customers should promptly inspect all Products upon delivery. The Customer must make claims for shortages within 20 days after the date of shipment from our factory or warehouse. We suggest that shortages be noted on the bill of lading or packing list, which should then be sent to our Customer Service Department for verification.

All other claims must be submitted within 60 days after the date of shipment from our factory or warehouse, or in the case of an alleged breach of warranty, within 60 days after the date within the warranty period on which the defect is or should have been discovered. Claims may not be deducted from payments made to us unless we have so agreed in writing in advance.

In the event of malfunction within the warranty period, Dynamix Agitators must be notified promptly, within thirty (30) days, if it is intended that the warranty is to cover the incident.

Warranty Data Sheet

To validate your warranty, please complete this form and return to:

Dynamix Agitators Inc.
#150-14480 River Road
Richmond, BC, Canada
V6V 1L4

Mixer Model Number _____ Serial Number _____
Purchase Order Number _____ Date Received _____
Tank Number or Location _____

Agitator Start Up Data

Date of Installation _____ Voltage at Start Up _____ V
DD/MM/YYYY

Full Load amperage measured with ammeter _____ Agitator shaft speed _____
RPM

Observed Level of Agitation: Gentle
Medium
Vigorous
Violent

Inspector: _____ Date: _____
Please print name clearly DD/MM/YYYY

Description of Process:

Comments:

Notes:

